

SERVICE DOORS *continued* technical support

CLEARANCE DETAILS

For dimensions of door sizes larger than shown or for other mountings or special conditions, refer to the factory.

PUSH-UP FACE OF WALL types SFP & AFP

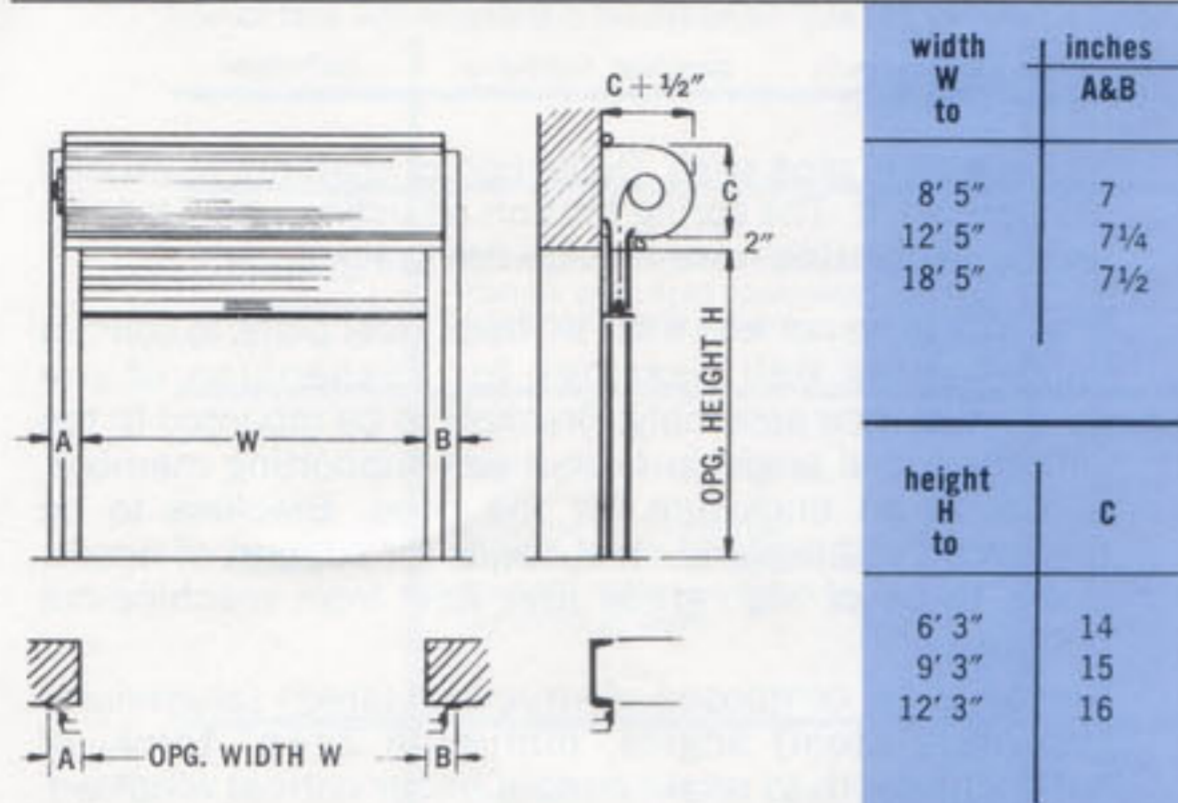

PUSH-UP BETWEEN JAMBS types SBP & ABP

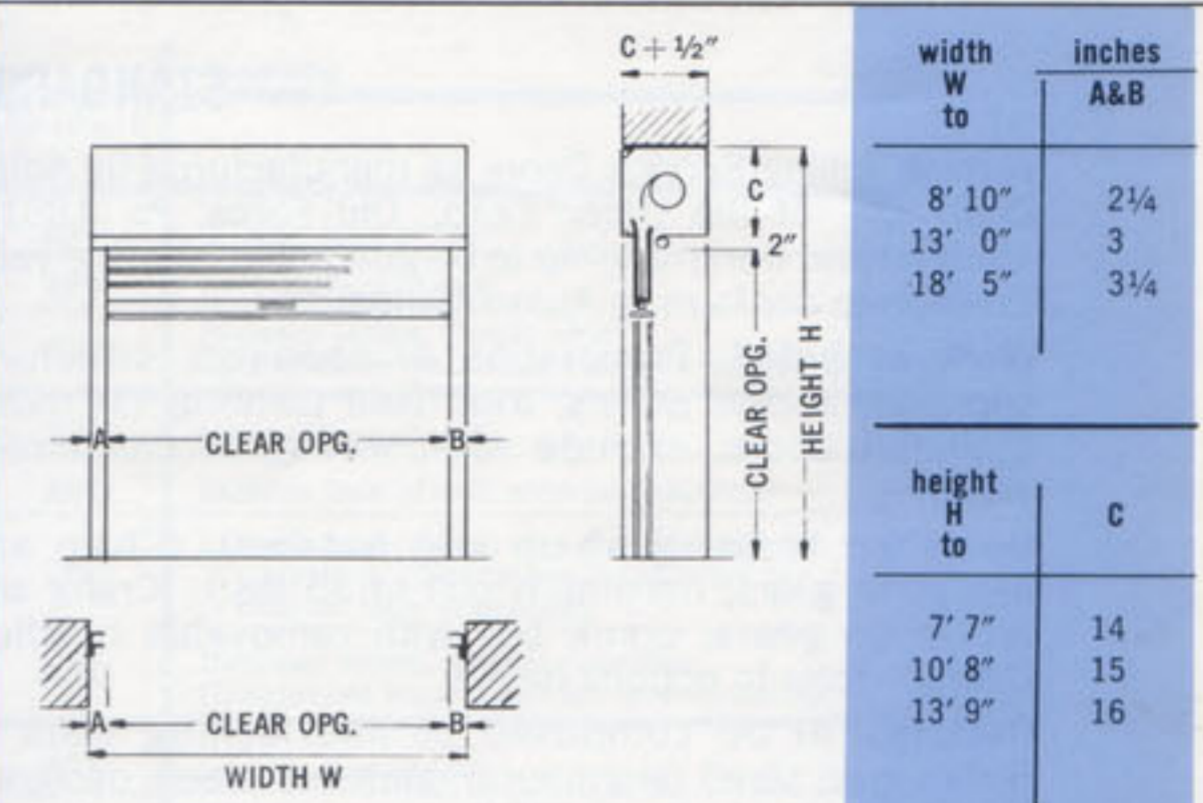

CHAIN FACE OF WALL types SFC & AFC

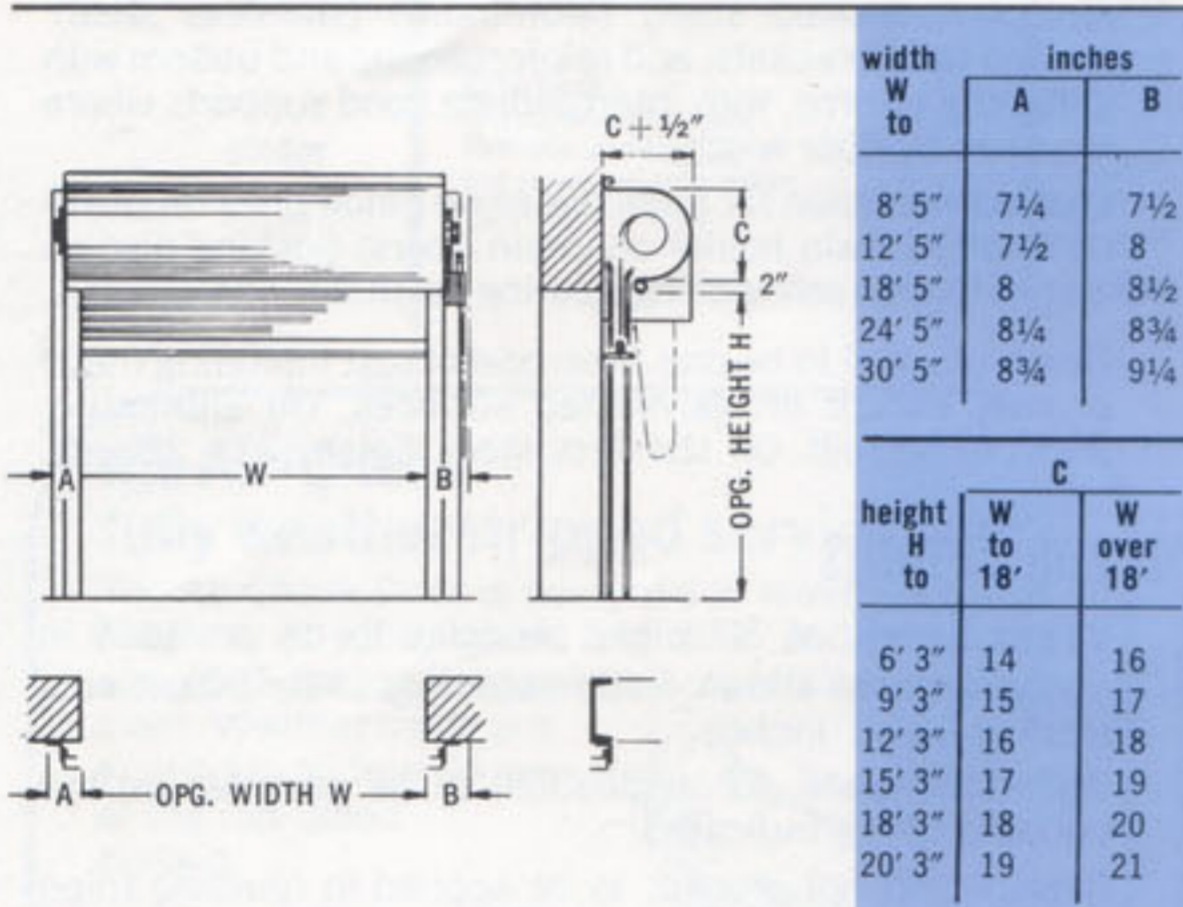

CHAIN BETWEEN JAMBS types SBC & ABC

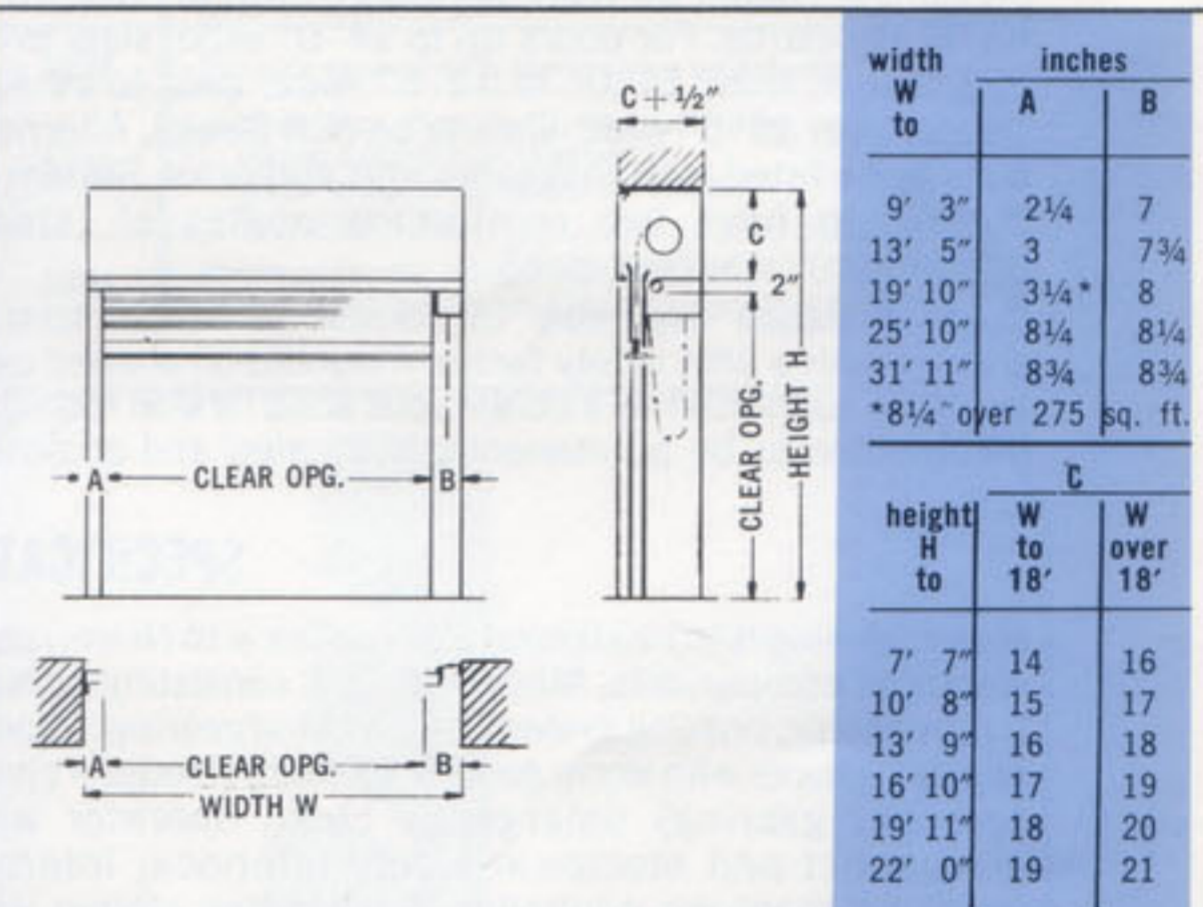

typical guide assemblies — for Standard Service Doors (for Air-Check doors, guide weatherstrip not shown)

face of wall

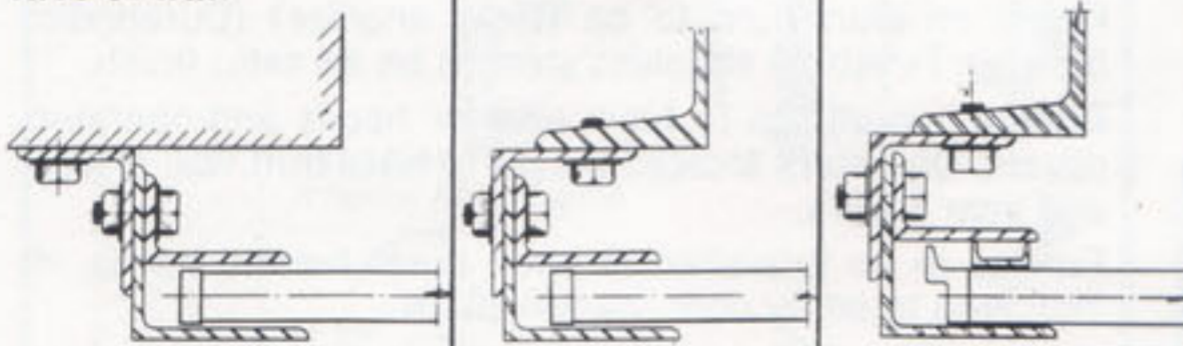

for fastening to masonry, using expansion bolts

for fastening to steel, using machine bolts

windlock guide for extreme windloads or wide openings

between jambs

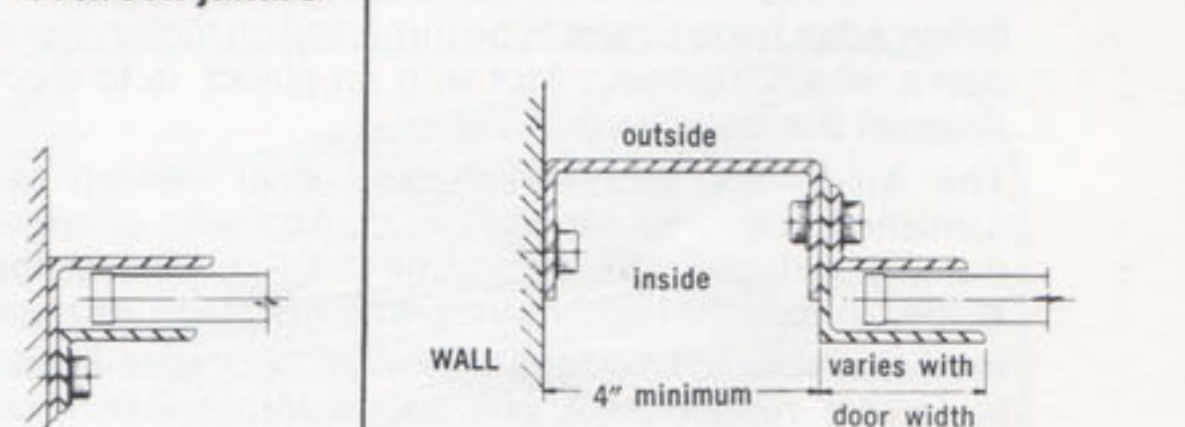

typical for push-up operation

typical for chain, crank, or motor operation